



LC275

LANDSCAPE PRO

**FERTILIZING, WATERING, WEED & FEED,
GENERAL GARDENING**

INSTRUCTION MANUAL

INDEX

Index	1
Unpacking	2 - 3
Specifications	4
Important Product Note	5
Warning	6
Caution	7
Wearing Protective Gear	8
Preparation for Spraying	9
Lock & Unlock the Pump Handle.	10
Wand Placement	11
Clean up, Storage & Transport	12
Maintenance	13
Replacement Parts - List	14 - 16
Nozzle & Performance	17
Return Instructions	18
Warranty Info	19

UNPACKING

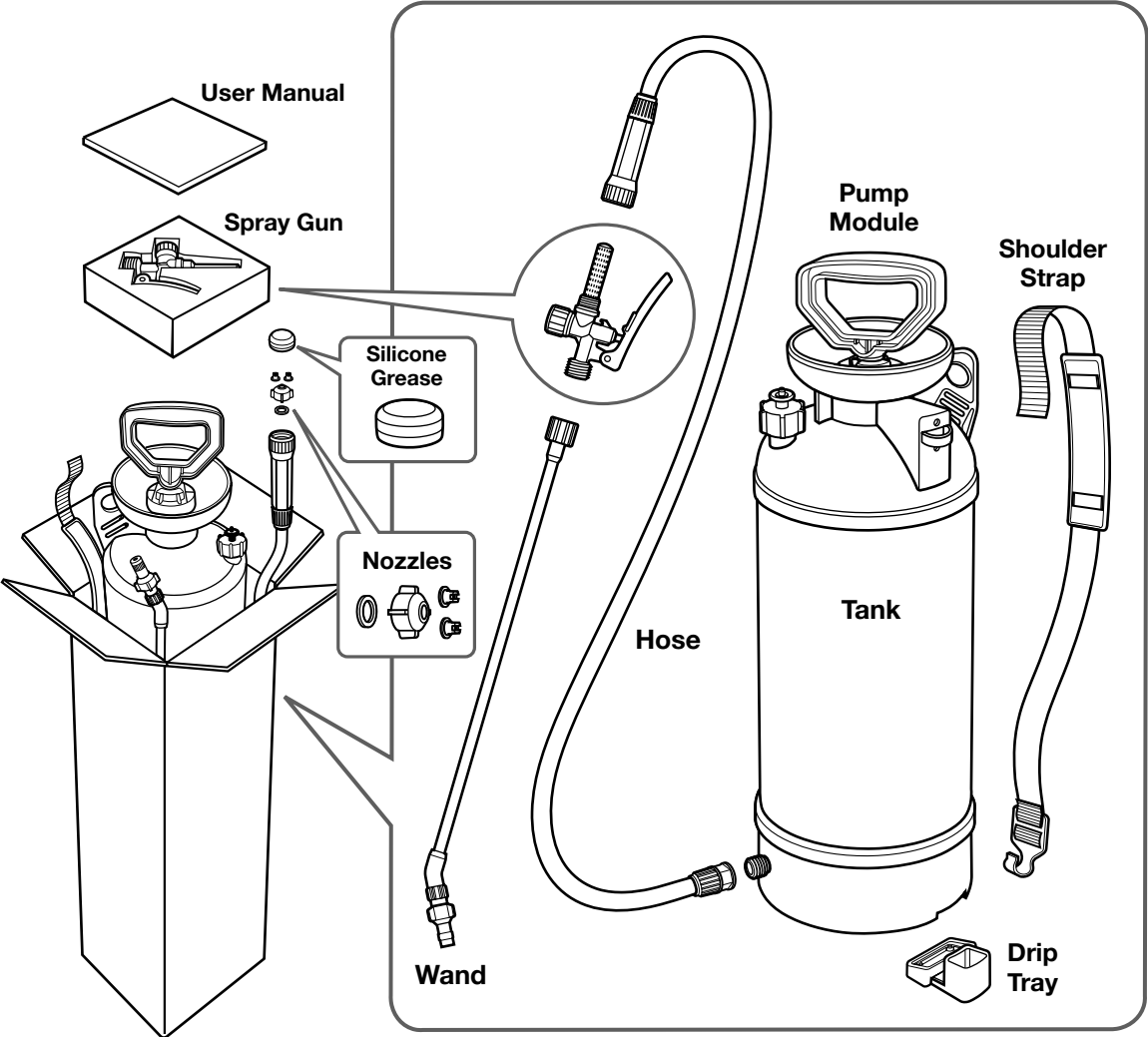

ASSEMBLY

Securely tighten the 6 locations indicated here to prevent leakage

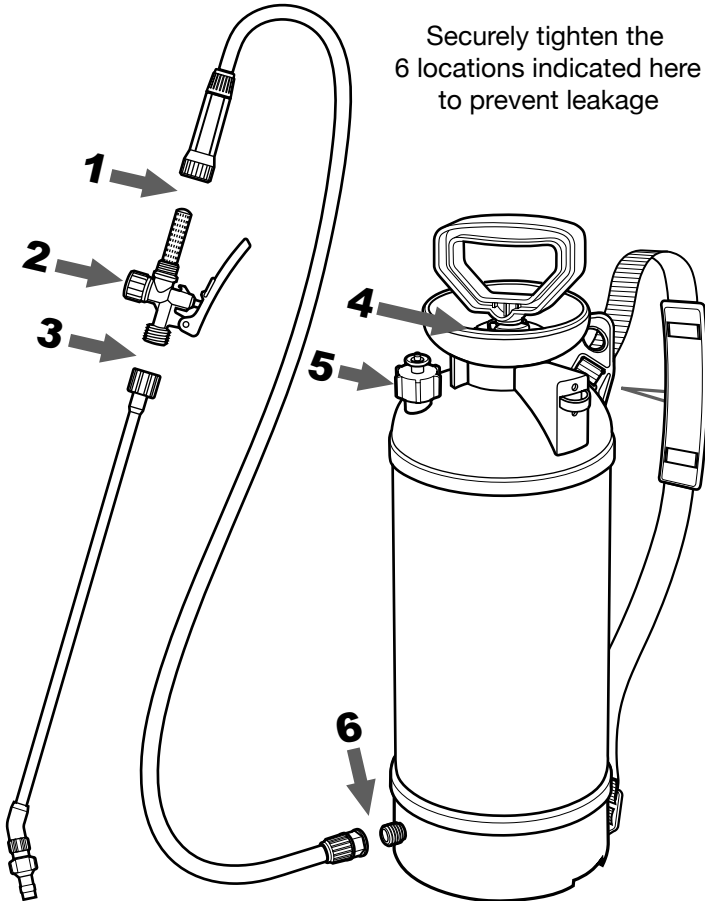

Attaching the Shoulder Strap to the tank:
From the top of the bottom, there are three slots to secure the strap on these slots.

Firstly, insert the strap to the first slot (upper) from the front, loop it back on the third slot (bottom).
Next, reinsert the strap to the middle spaces from the front, and loop it back again on the upper slot.

Finally, attach the plastic hook at the end of the strap to the slot at the bottom of the tank.

Snap the Drip Tray to the bottom of the tank



NOTE: Residual water may be accumulated in the tank and hose during factory quality and performance testing. This is normal.

SPECIFICATIONS

LC275 LANDSCAPE PRO

Target Market	Industrial Construction Engineered for spraying herbicides, pesticides, insecticides, fungicides, weeds & feeds, fertilizers; also for watering and general gardening, general cleaning, household bleach maximum dilution 1:10
CAUTION: If you have any questions about chemical compatibility, please contact us at info@sprayers-plus.com	
Pump Type	Compression Pump
Capacity - US Gallons (Litres)	2 (7.6)
Dry Weight - lbs (kg)	5.5 (2.5)
Seals & O-rings	Viton ^R
Spray Gun	SprayersPlus TM with Lock Pin & Filter
Wand	20" Brass (powder coated)
Hose	51" Reinforced PVC (Black)
Pressure Range (PSI)	
Working Pressure	15 - 60
Pressure Release Valve Auto Activation	98 +/- 2
Nozzles	
Standard Nozzle (brass)	Adjustable From Cone to Stream
Fan Nozzle A (plastic)	90°
Fan Nozzle B (plastic)	110°
Shoulder Strap	Comfortable Padding / Adjustable Length
Mouth Opening - inch	5.24" QuickFill
Warranty	1 Year

IMPORTANT PRODUCT NOTE

SprayersPlus produces top quality products meeting the highest standards in the industry.

To ensure your safety, optimize the user experience and maximize the life span of this product, it is of utmost importance to follow the product instructions, as well as the DOs and DON'Ts outlined in the operation and maintenance procedures of this manual.

Please read this manual thoroughly and follow carefully.

Be sure you understand how to operate this unit properly before you use it. Failure to do so could result in serious injury.

Keep this manual handy so that you may refer to it later whenever any questions arise. Contact the dealer from whom you purchased the product for assistance in the event you have any questions which cannot be answered herein.

Include this manual when selling, lending, or otherwise transferring the ownership of this product. Do not lend or rent your machine without the owner's manual.

Be sure that anyone using your unit understands the information contained in this manual.

SAFETY GUIDELINES - DEFINITIONS

It is important to read and understand this manual. The information contains relates to protecting YOUR SAFETY and PREVENTING PROBLEMS. The symbols below are used to help you recognize this information.



DANGER!

Indicates an imminently hazardous situation which, if not avoided will result in death or serious injury.



WARNING!

Indicates a potentially hazardous situation which, if not avoided, could result in death or serious injury.



CAUTION!

Indicates a potentially hazardous situation which, if not avoided, may result in minor or moderate injury.

Contact us if you have any question or concern: info@sprayers-plus.com



WARNING!

IMPROPER USE OR FAILURE TO FOLLOW INSTRUCTIONS CAN RESULT IN EXPLOSION CAUSING SERIOUS EYE OR OTHER INJURIES.

FOR THE SAFE USE OF THIS SPRAYER, YOU MUST READ AND FOLLOW ALL INSTRUCTIONS.

- Anything to be sprayed must match the specifications of the tank, hose, seals and accessories. Spraying incompatible chemicals and solutions can be hazardous to the user; that can also damage the product.
- DO NOT use flammable in the sprayer. They can ignite or explode causing serious injury.
- Do not attempt to modify this sprayer. Replace parts with manufacturer's original parts only.
- Never let a child under age 13 use this product.
- Do not exceed a tank solution temperature of 120°F/49°C. Do not leave a pressurized sprayer in the hot sun. Heat can cause pressure to build up, resulting in possible explosion.
- Always wear goggles, gloves, long sleeve shirt, long pants and full foot protection while spraying and/or when cleaning the product.
- Keep the breather hole in the lid clear of debris and dirt to proper allow air flow into the tank. Without a proper breather hole opens, the tank may collapse or crack due to the air vacuum from pumping.
- Handling the brass parts of this product will expose you to a chemical known to the state of California to cause birth defects or other reproductive harm.
- Never over-pressurize the unit. Do not attempt to pressurize the unit by any other method than with the pump module provided.
- Do not eat, drink, or smoke while spraying.



CAUTION!

- Refrain from operating the sprayer if you are tired, ill, or upset, or if you are under the influence of alcohol, drugs or medication.
- To reduce the risk of injury, always wear proper protective clothing and gears when filling, using and/or cleaning the sprayer. Eye protection should meet the requirements of ANSI Z87.1.
- Wear appropriate mask or respirator when filling, using and cleaning the sprayer according to the recommendation by the manufacturer of the chemical or solution you are using.
- Wear sturdy rubber-soled shoes or shoes with anti-slip protection to help protect you against falling when filling, using and/or cleaning the sprayer.
- Do not wear loose clothing, scarves, neck chains, hair longer than shoulder length when filling, using and/or cleaning the sprayer.
- In case of personal contamination: remove contaminated clothing, remain upright, do not consume liquids or cause vomiting, and get professional help immediately.

PRE-USE CHECK:

- Lubricate the rubber lid o-ring with Silicone Grease prior to first usage to ensure it seals properly.
- Before each use, check the tightness of all connections: the lid, the hose, the trigger, the nozzle and the wand.

PREPARATION FOR SPRAYING

WEAR PROTECTIVE GEAR

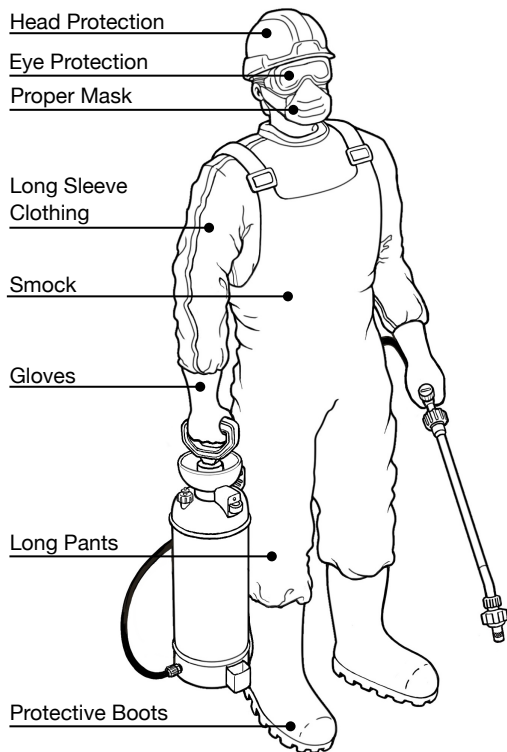

Follow Occupational Health and Safety regulation.

Wearing protective clothing and equipment when handling chemicals is obligatory.

⚠ WARNING:

Use the correct dose and volume of chemical according to the product label.

⚠ WARNING:

Do not spray near springs, lakes, rivers and people who are not using PPE.

⚠ WARNING:

In case of an accident, remove the sprayer immediately.

PREPARATION FOR SPRAYING

- Always inspect your sprayer thoroughly before and after each use. Check to be sure everything is securely attached and in good condition before pressurizing the tank.
- Check the work area that the sprayer will be used in and remove or cover all valuables that may be damaged by using sprayer.
- To reduce the risk of injury:
 - ❖ Watch out for children, pets, open windows, freshly washed cars. Spray safely (away from those).
 - ❖ Do not allow bystanders in work area.
 - ❖ Do not point the sprayer nozzle in the direction of people or pets.
 - ❖ Pay attention to the direction of breeze, do not work against the it.
 - ❖ Never use the sprayer during windy conditions.
 - ❖ Never point a sprayer nozzle toward an open flame, this is to avoid the possibility of ignition or explosion which may cause injury to yourself or damage to surroundings.
 - ❖ Always release pressure in the pump prior to filling, cleaning, or servicing the sprayer.
 - ❖ Before opening a container of pesticide or other hazardous materials, carefully read, understand, and follow all instructions on the label.
- Mix your chemicals in a separate container, then fill the sprayer. Do not mix formulas inside the sprayer except with liquid fertilizers: fill sprayer with water BEFORE adding the active ingredient.
- Always sift the chemical/formula (with a screened funnel or strainer).
- Never fill the sprayer with hot liquids. Max. 30°C, or 85°F.

PREPARATION FOR SPRAYING

LOCK & UNLOCK THE PUMP HANDLE

This pump handle is also engineered for carrying/transporting the unit when it is in the **locked** position. To **unlock** the handle (from the locked position), gently turn it clockwise.

When the handle is in the **unlocked position**, it can slide up and down smoothly to pump air into the tank.

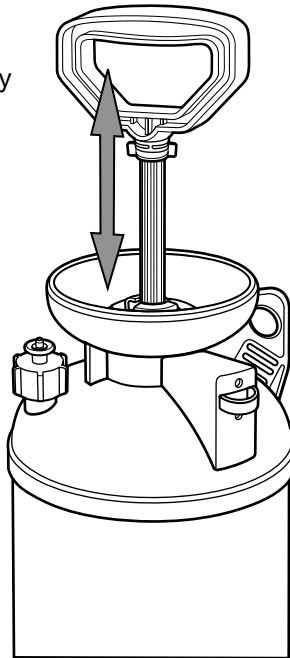
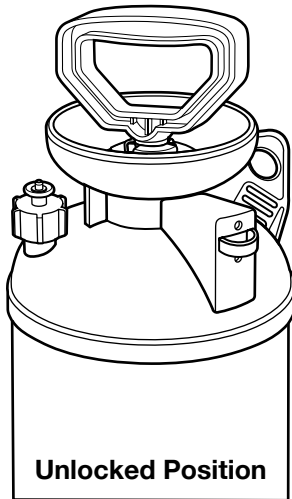

To **lock** the handle (from the unlocked position), make sure it is pushed all the way down to the tank and gently **turn it counterclockwise** until you feel a "click".

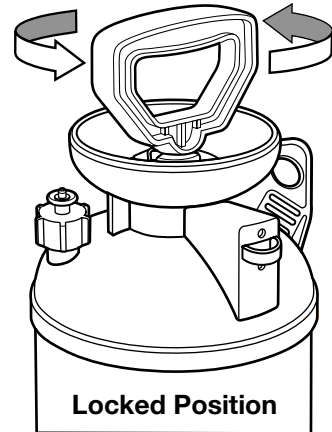

PREPARATION FOR SPRAYING

WAND PLACEMENT

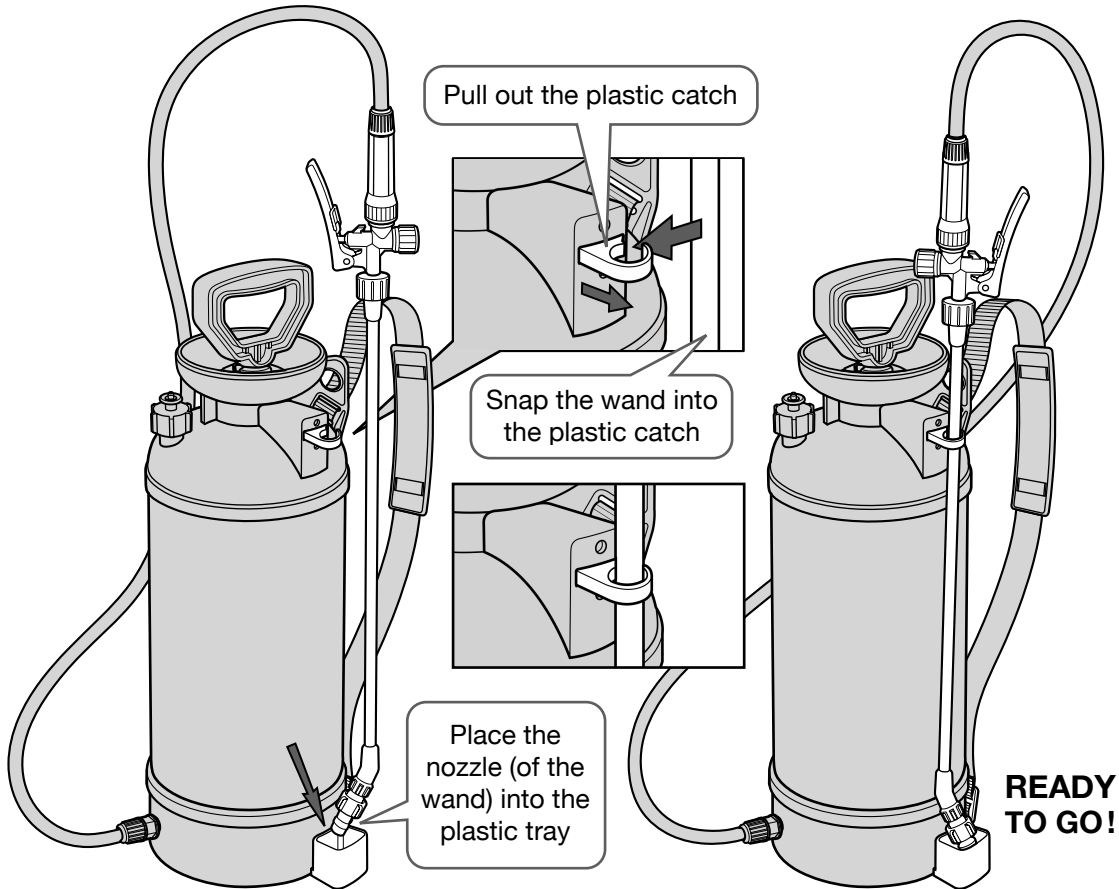

CLEAN UP, STORAGE & TRANSPORT

- After using the sprayer, CLEAN UP (unless spraying is to be continued within hours). Dispose the chemical or solution appropriately, and rinse the tank with fresh water.
- Before cleaning or servicing the sprayer, depressurize by pulling the valve upwards.
- To thoroughly clean the system, fill the tank with 1/2 gallon of fresh water, pressurize, and flush the system by pressing trigger for at least two minutes; then drain the remaining water.
- Wash your face and hands after spraying; wash your hands after handling any chemical.
- Clean and rinse tank and spraying assembly after each use to prevent crystallizing, which would later cause clogging and chemical damage to the unit.
- Do not store the sprayer under pressure or with spray solution in tank. Store it empty and dry.
- Do not transfer spray materials to other containers that are used for food and/or drink.
- Keep spray materials locked up and out of reach of children and animals. Do not leave the sprayer in reach of children or persons not qualified to properly handle it.
- When not in use, and especially during prolonged storage, keep your sprayer in a protected place away from direct sunlight or extreme low temperature.
- Make sure the spray hose loops freely without kinking or squeezing.
- Transportation: Do not store or transport sprayer under pressure. Drain the content from the tank before transporting or storing the sprayer. Secure the unit carefully to prevent movement when it is transported. A unit that receives a strong shock during transport and unloading may malfunction.

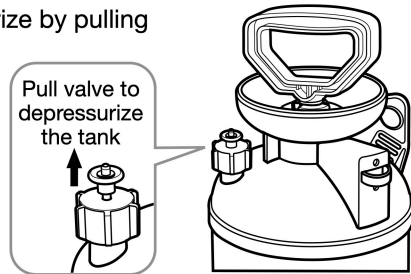

IMPORTANT: Depressurize the unit if it will not be used for more than 30 minutes.

This action helps reduce continuous stress on the tank, hose, and seals, thereby prolonging the life of your sprayer.

MAINTENANCE

Units are not storage tanks and should be washed and cleaned after each use. Failure to maintain the unit may damages the o-rings and seals and may void the manufacturer's warranty. Lubricate all moveable rubber pieces (o-rings, seals), spindle in the gun and piston cup (if applicable) with Silicone Grease.

Clean and Wash

Using a brush, clean the sprayer thoroughly at the points indicated after each use.

Soap can be added to the water for a better cleaning result.

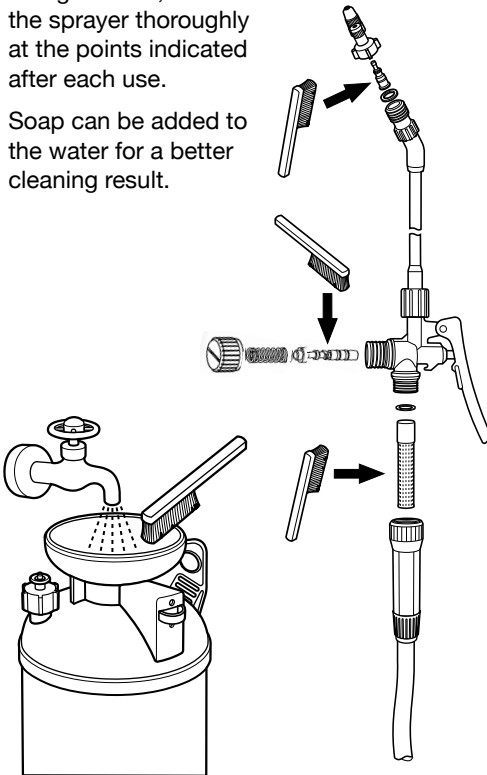

Rubber Seal Protection & Lubrication

To prolong the life of the sprayer and maintain good performance, lubricate at all the point(s) indicated as well as all moveable rubber pieces with silicone grease.

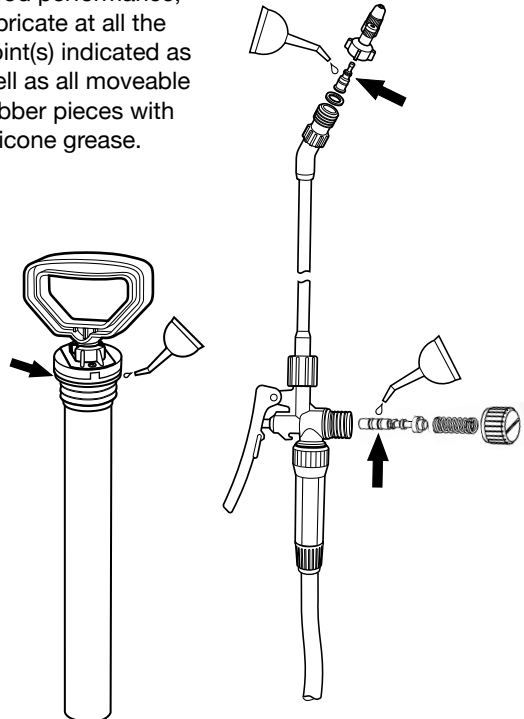

REPLACEMENT PARTS - DIAGRAM A

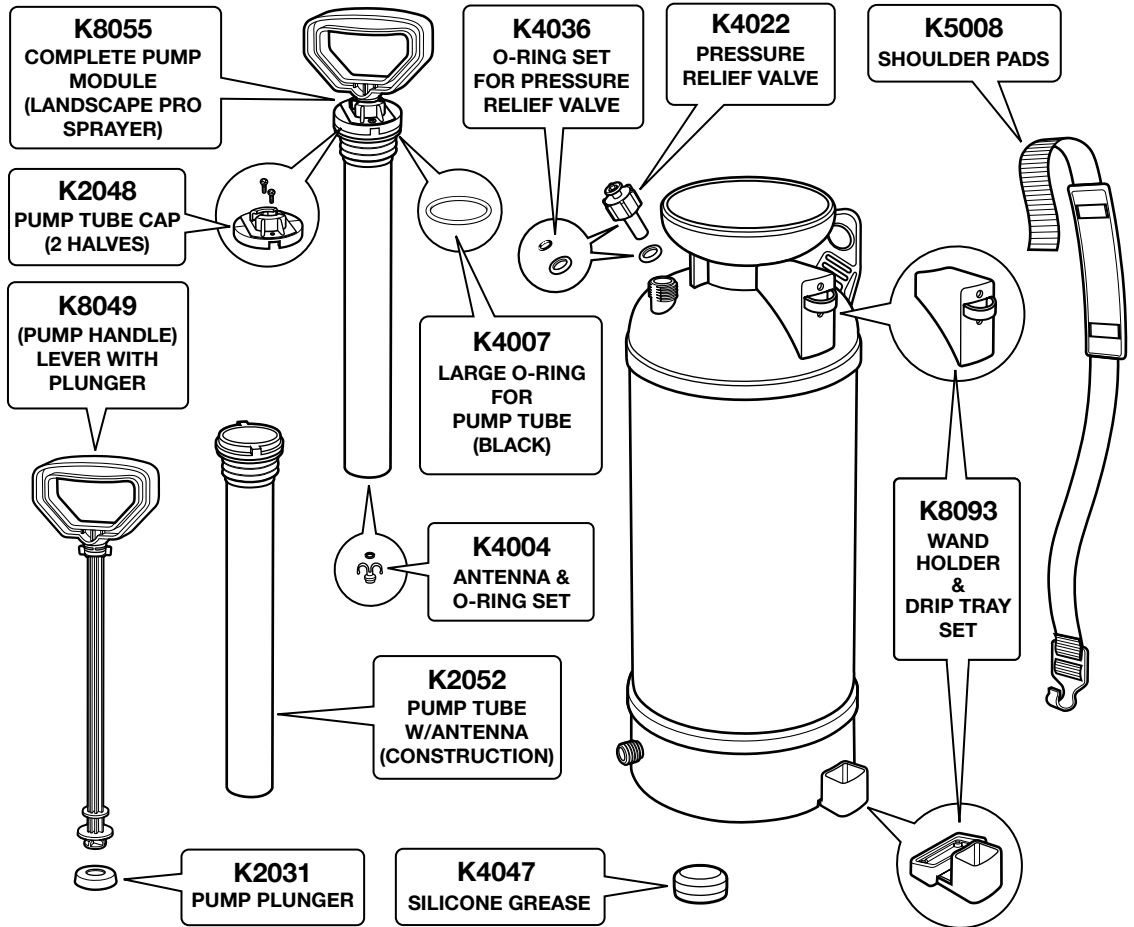

REPLACEMENT PARTS - DIAGRAM B

HOSE, WAND AND O-RINGS

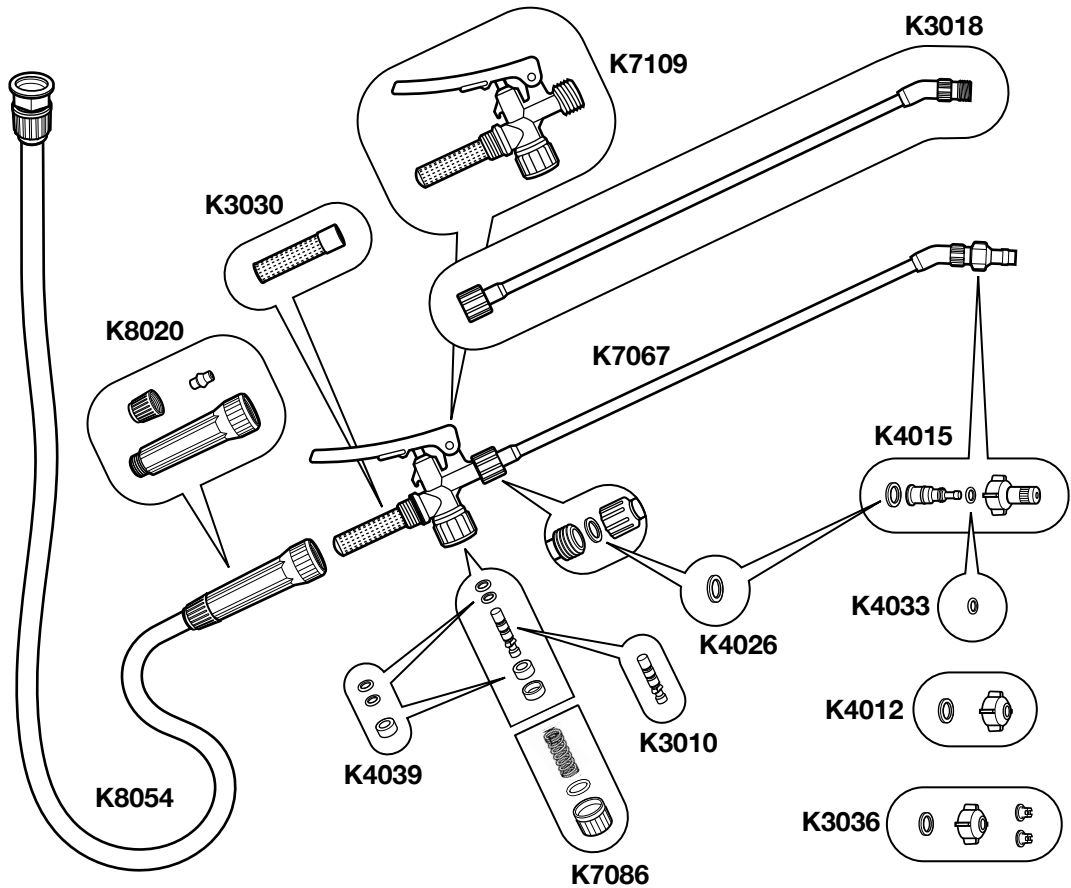







REPLACEMENT PARTS - LIST

K2031	PUMP PLUNGER	K4036	O-RING SET FOR PRESSURE RELIEF VALVE
K2048	PUMP TUBE CAPS (2)	K4039	SPINDLE SEAL
K2052	PUMP TUBE W/ O-RING & ANTENNA	K4047	SILICONE GREASE
K3010	BRASS SPINDLE SET	K5008	SHOULDER PADS W/SS HOOK
K3018	BRASS SPRAY WAND - 20"	K7067	SPRAY GUN A6
K3030	SPRAY GUN FILTER	K7086	PLUG SET - SPRAY GUN
K3036	PLASTIC SPRAY TIP SET	K7109	SPRAY GUN A PART SET
K4004	ANTENNA & O-RING	K8020	NEW GRIP SET (SCREW-IN STYLE)
K4007	LARGE O-RING FOR PUMP TUBE (BLACK)	K8049	LEVER WITH PLUNGER
K4012	NOZZLE HOLDER (CONSTRUCTION)	K8054	PVC HOSE SET
K4015	COMPLETE ADJUSTABLE BRASS NOZZLE (VITON)	K8049	LEVER WITH PLUNGER
K4022	PRESSURE RELIEF VALVE	K8055	COMPLETE PUMP MODULE (LANDSCALE PRO SPRAYER)
K4026	WASHERS SET FOR SPRAY GUN (VITON)	K8093	WAND HOLDER & DRIP TRAY SET (LANDSCALE PRO SPRAYER)
K4033	VITON O-RING FOR ADJUSTABLE NOZZLE		

To order parts, please email: info@sprayers-plus.com or scan QR code
For more specifications and information, go to webpage: www.sprayers-plus.com



NOZZLE & PERFORMANCE

Type	Sprayer Models	Pressure (psi/kg)	Mist setting output (ml/min) +/- 100ml	Coverage @ 3.3' height (feet)	Steam setting output (ml/min) +/- 100ml	Steam setting Horizontal reach (feet)
 Brass Cone 1.3mm Orifice	100, 101, 103, 201, 202, 401, 402	40/2.8	700	3.9' x 3.9'	1100	33'
	CR275, LC275, YT10, YT20, YT30, 20C, 35C, PS20	32/2.16	500	2.5' x 2.5'	900	32'
	105EX	40/2.8	800	3.9' x 3.9'	1150	35'
	YT25	32/2.16	500	2.5' x 2.5'	900	32'
	603	32/2.16	500	2.5' x 2.5'	900	32'
 Black Cone 1.5mm Orifice	301, 302, 403	32/2.16	580	3.9' x 3.9'	1520	32'
	10ACID, 20ACID, 20ACT, 35ACT, FH10, FH20, FH30, BL20, AD275, AT275	32/2.16	580	3.9' x 3.9'	1520	32"
	601	32/2.16	520	3.9' x 3.9'	1450	32"
	701, 703	32/2.16	430	3.6' x 3.6'	730	16"
	801, 802, 803	n/a	230 +/- 10ml (2.8ml/puff)	3.9' x 3.9'	360 +/- 10ml (3.4ml/puff)	25"
 Black Cone 1.0mm Orifice	BL25E, FH25E	32/2.16	440	3.6' x 3.6'	730	31"
 02 Yellow Fan 90°	100, 101, 103, 201, 202, 301, 302, 401, 402, 403,	40/2.8	1000	n/a	n/a	n/a
	CR275, LC275, AD275, AT275, 20C, 35C, 10ACID, 20ACID, 20ACT, 35ACT, BL20, PS20, YT10 YT20, YT30, FH10, FH20, FH30	32/2.16	850	n/a	n/a	n/a
	BL25E, FH25E, YT25E	32/2.16	680	n/a	n/a	n/a
	601, 603	32/2.16	750	n/a	n/a	n/a
	801, 802, 803	n/a	260 +/- 10ml (2.3ml/puff)	n/a	n/a	n/a
 03 Blue Fan 110°	100, 101, 103, 201, 202, 301, 302, 401, 402, 403,	40/2.8	1150	n/a	n/a	n/a
	CR275, LC275, AD275, AT275, 20C, 35C, 10ACID, 20ACID, 20ACT, 35ACT, BL20, PS20, YT10 YT20, YT30, FH10, FH20, FH30	32/2.16	1450	n/a	n/a	n/a
	105Ex	40/2.8	1350	n/a	n/a	n/a
	BL25E, FH25E, YT25E	32/2.16	1200	n/a	n/a	n/a
	601, 603	32/2.16	1300	n/a	n/a	n/a
801, 802, 803	n/a	340 +/- 10ml (3.3ml/puff)	n/a	n/a	n/a	
 04 Gray Fan 135°	105E, 105Ex	40/2.8	1620	n/a	n/a	n/a

RETURN INSTRUCTIONS

If it is necessary to return the sprayer for repair, always perform the following tasks before returning the sprayer:

- In an approved containment area, flush chemical residue from the pump, tank and hoses.
- Circulate fresh water through the tank, pump and hoses.
- Indicate the type of chemicals that have been in the sprayer with a label or tag.
- Include complete description of operation problem, such as how sprayer was used, symptoms of malfunction, how many working hours per day, etc.
- Since the sprayer can contain residues of toxic chemicals, these steps are necessary to protect the people who handle return shipments and to help identify issues and solutions.



WARRANTY INFORMATION

Statement of Limited Warranty

Sprayers Plus shall warrant the equipment described in this manual and shall repair or replace parts and components which, under normal operation and wear, in accordance with technical recommendations, show DEFECTS IN MATERIAL OR WORKMANSHIP, based on the following conditions.

Warranty period

Every sprayer is covered by a one-year warranty against defects in workmanship and materials, with a 6-month limited warranty on consumable parts from the date of sale to the original purchaser.

Warranty Registration

Please visit: www.sprayers-plus.com/warranty

Sprayers Plus shall honor this warranty, free of charge, if any part or component shows defect in MATERIAL OR WORKMANSHIP, after final analysis at the factory.

This Warranty shall be null and void in case of:

- Misuse of the equipment against specifications in this manual, overwork or accidents.
- Preventive / remedial maintenance performed by unauthorized people or parties.
- Use of parts and components not supplied by Sprayers Plus.
- Modification of the equipment or any characteristic of the original design.

This Warranty shall exclude

- Parts which show wear and tear due to use: spray nozzle, filters, seals, rechargeable battery, hydraulic pump, electronic panel, charger and its cables, agitator lever, belt, UNLESS THEY SHOW DEFECTS IN WORKMANSHIP, ASSEMBLY OR MATERIAL.
- Damages resulting from accidents.
- Transportation or freight of the equipment, parts, and components in case such warranty is not approved.
- Transportation and travel time of technician.

web: www.sprayers-plus.com



email: info@sprayers-plus.com